

XG Category 6A Shielded Patch Panels

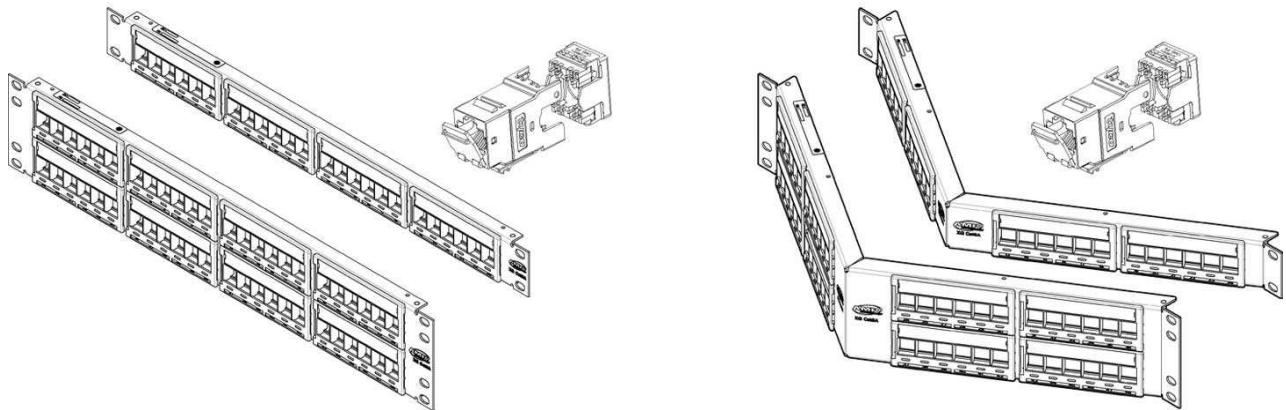

1933319-2, 1933320-2, 1933321-2, 1933322-2



Description

AMP NETCONNECT XG Category 6A shielded patch panels meet or exceed channel specifications of ANSI/TIA/EIA-568-B.2-10:2008 Category 6A and ISO/IEC 11801:2002/Amd 1:2008 Class EA up to 500 MHz when used as a component in a properly installed AMP NETCONNECT XG F/UTP channel. The AMP NETCONNECT XG Category 6A F/UTP System complies with all of the performance requirements for current and proposed applications such as Gigabit Ethernet (1000BASE-Tx), 10/100BASE-Tx, token ring, 155 Mbps ATM, 100 Mbps TP-PMD, ISDN, analog and digital video, analog and digital voice (VoIP), and exceeds all requirements for IEEE 802.3an 10 Gigabit Ethernet on all parameters and RoHS Compliant.

XG shielded patch panels feature patent-pending integrated bonding technology allowing each AMP-TWIST modular jack (included with, but packaged separately from the panel) to be bonded together simply by snapping each jack into the interface housing. Each interface housing accommodates traditional labeling and icons and is front loadable, so installations are easier in tight spaces. Panels are shipped with and 8.5"x11" card stock label sheet. Labels are removable/replaceable and are intended to be secured in the panel by clear, snap-in label covers that are included with each panel. Panels can also accommodate adhesive labels. Best of all the panels look like standard UTP panels when installed, so your equipment room looks neater and more organized.

AMP NETCONNECT AMP-TWIST XG modular jacks have a slim profile and offer universal wiring labels which permit termination to either T568A or T568B wiring patterns. The modular jacks feature a robust, die-cast metal body which creates an integral shield. Cables are dressed at 180° (rear entry) and modular jacks include an integrated lacing fixture for use with the SL Series modular jack termination tool (1725150). The modular jacks contain integrated cutting blades used during termination to eliminate the need to manually trim conductors and to allow all four pairs of a four pair cable to be terminated at one time.

Specification (text in brackets [] requires a choice)

Patch panels shall be [standard or angled] foot print, [1U, 24-port or 2U, 48-port], and shall accept SL Series form factor modular jacks and inserts. Patch panels shall be configured with front-loadable 6-port modules with individually replaceable ports, and accept optional icons and standard labeling. Each 6-port module shall feature an integrated bonding bar which shall create a continuous ground path for each module. Patch panels shall be supplied unloaded with jacks packaged separately, for termination using AMP NETCONNECT SL Series Termination Tool (p/n: 1725150). Panels shall accommodate removable/replaceable labels that are secured by snap-in label covers.

Modular jacks shall be unkeyed, 4-pair, RJ-45, with an integrated shield and shall fit in a .790" X .582" opening. Modular jacks shall terminate using the AMP NETCONNECT SL Series modular jack termination tool part number 1725150-3 (or 1725150-1 after removing the tool's lacing fixture), and be color-coded for both T568A and T568B wiring. Each jack shall contain integrated cutting blades to automatically trim conductors during termination. Each modular jack shall be wired to [T568A or T568B] and shall accommodate cable with a maximum O.D. of 9.00 mm. The insulation displacement contacts shall be capable of terminating 24-22 AWG solid or 26-24 AWG stranded conductors with a maximum insulation diameter of 1.60 mm. The insulation displacement contacts shall be paired, with additional space between pairs to improve crosstalk performance. Modular jacks shall utilize a secondary PC board, separate from the signal path, for crosstalk compensation. Each modular jack shall meet the TIA/EIA-568-B.2-10, Category 6A performance standards and the requirements listed in the following table.

[Include Performance Characteristics table from page 2]

Modular Jacks shall be independently tested for performance to the following specifications:

1. ANSI/TIA/EIA-568-B.2-10
2. ISO/IEC 11801:2002/Amd 1:2008
3. IEEE 802.3an

Patch panels shall be AMP NETCONNECT part number [1933319-2, 1933320-2, 1933321-2 or 1933322-2].

XG Category 6A Shielded Patch Panels



1933319-2, 1933320-2, 1933321-2, 1933322-2

Part Numbers

Description	EIA/TIA Category [ISO/IEC Class]	Included Modular Jacks	Panel Form Factor	Port Count	Height	Part Numbers
XG Shielded Patch Panels	6A [EA]	Packaged Separately	Standard	24	1U (1.75 in)	1933319-2
				48	2U (3.5 in)	1933320-2
			Angle	24	1U (1.75 in)	1933321-2
				48	2U (3.5 in)	1933322-2

Channel Performance Characteristics (meet or exceed ANSI/EIA/TIA, ISO/IEC and IEEE requirements)

Frequency (MHz)	Insertion Loss (dB)	NEXT (dB)	PSNEXT (dB)	ACRF (dB)	PSACRF (dB)	Return Loss (dB)	Prop Delay (ns/100m)	Prop Delay Skew (ns)	TCL (dB)	ELTCL / TCTL (dB)	PSANEXT (dB)	PSAACRF / PSAFEXT (dB)
0.772	2.1	65.0	62.0	65.5	62.5	19.0	585.0	50.0	40.0	32.2	67.0	67.0
1	2.3	65.0	62.0	63.3	60.3	19.0	580.0	50.0	40.0	30.0	67.0	67.0
4	4.2	63.0	60.5	51.2	48.2	19.0	562.0	50.0	40.0	18.0	67.0	65.0
8	5.8	58.2	55.6	45.2	42.2	19.0	556.7	50.0	39.5	11.9	67.0	58.9
10	6.5	56.6	54.0	43.3	40.3	19.0	555.4	50.0	38.0	10.0	67.0	57.0
16	8.2	53.2	50.6	39.2	36.2	18.0	553.0	50.0	34.9	5.9	67.0	52.9
20	9.2	51.6	49.0	37.2	34.2	17.5	552.0	50.0	33.5	4.0	67.0	51.0
25	10.2	50.0	47.3	35.3	32.3	17.0	551.2	50.0	32.0	2.0	66.0	49.0
31.25	11.5	48.4	45.7	33.4	30.4	16.5	550.4	50.0	30.4	N/A	65.1	47.1
62.5	16.4	43.4	40.6	27.3	24.3	14.0	548.6	50.0	24.4	N/A	62.0	41.1
100	20.9	39.9	37.1	23.3	20.3	12.0	547.6	50.0	20.3	N/A	60.0	37.0
200	30.1	34.8	31.9	17.2	14.2	9.0	546.5	50.0	14.3	N/A	55.5	31.0
250	33.9	33.1	30.2	15.3	12.3	8.0	546.3	50.0	12.3	N/A	54.0	29.0
300	37.4	31.7	28.8	13.7	10.7	7.2	546.1	50.0	10.8	N/A	52.8	27.5
400	43.6	28.7	25.8	11.2	8.2	6.0	545.8	50.0	8.3	N/A	51.0	24.9
500	49.3	26.1	23.2	9.28	6.3	6.0	545.6	50.0	6.3	N/A	49.5	23.0

Technical Details

Materials

Modular Jack and Lacing Fixture Housing	Zinc Alloy
IDC Connecting Block	Polycarbonate, 94V-0 rated
Contacts	Beryllium copper, plated with 1.27 µm [50 µin] thick gold in localized area and 3.81µm [150 µin] minimum thick nickel under plate and 3.8 µin minimum thick tin-lead in solder area over 1.27 µm minimum thick nickel under plate
Cutting Blade and Shield Point Contact	Stainless Steel
Insulation Displacement Contacts	Phosphorous bronze, plated with 3.81 µm [150 µin] minimum thick matte tin over 1.27 µm [50 µin] minimum thick nickel under plate
Connector Housing Interface (6-Pack Module)	Polyester molding compound, black
Panel	Steel, black powder coat
Screws	12-24 x 0.5 in [12.7 mm], carbon steel, black, cross recessed 10-32 x 0.5 in [12.7 mm], carbon steel, black, cross recessed

Electrical Characteristics

Voltage	150VAC max.
Operating Temperature	-40° to 70°C (-40° to 158°F)

Mechanical Characteristics

Modular Jack	750 mating cycles
Insulation Displacement Contacts	Accept solid, 24-22 AWG conductors or stranded 26-24 AWG conductors with a maximum insulation diameter of 1.60 mm
Cable Outside Diameter	Accepts cables with a maximum O.D. of 9.00 mm

Specifications subject to change without notice. Revised 06/08

<http://www.ampnetconnect.com/thailand>

